

T&A TOOL, Inc.

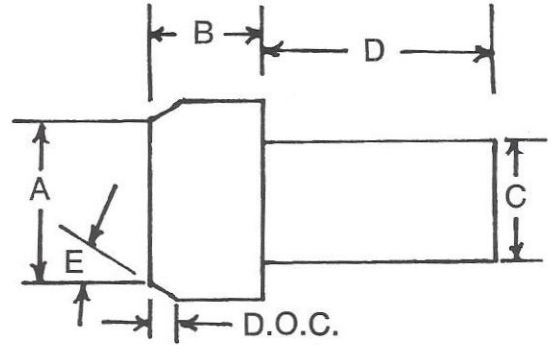

MILLING CUTTER SET ——— **MC 7 - 1N**

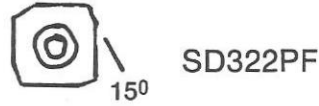

MILLING CUTTER ORDER EXAMPLE

FM — Face Mill

EM — End Mill

CCEM — Center Cutting End Mill

FM — 1 — 2° — 3 — .75
 Face Mill Cut Dia. Lead Angle No. of Inserts Shank Dia.

*Must specify larger shank when ordering set.

AVAILABLE INSERTS

Style	Grade	APPLICATION
SD322PA	TA23	Non-Ferrous, High-Temp. Alloys
SD322PF	TA23	Non-Ferrous, High-Temp. Alloys
SD322PA	TA50	Steel (Uncoated)
SD322PA	TAC113	Steel, Stainless Steel, Cast Iron (Tin Coated)
SD322PF	TAC113	Steel, Stainless Steel, Cast Iron (Tin Coated)

TOOL #	A	B	C	D	E	D.O.C.	Center Cut	Ramp Mill	Max. R.P.M.	Ins.	Screw
CCEM 1.0-0°-5-.75	.980	1.5	.750	2.0	0°	1.188	YES	8°	3000	5	S-1
FM 1-2°-3-.75	1.0	1.0	.750	2.0	2°	.350	NO	NO	3000	3	S-1
FM .9-15°-3-.75	.9	1.0	.750	2.0	15°	.325	NO	8°	3000	3	S-1
FM 1.5-15°-4-.75	1.5	1.0	.750	2.0	15°	.325	NO	8°	2000	4	S-1
*FM 1.5-15°-4-1.0	1.5	1.0	1.000	2.0	15°	.325	NO	8°	2000	4	S-1
FM 2.1-15°-5-.75	2.1	1.0	.750	2.0	15°	.325	NO	8°	1500	5	S-1
*FM 2.1-15°-5-1.0	2.1	1.0	1.000	2.0	15°	.325	NO	8°	1500	5	S-1
FM .9-30°-3-.75	.9	1.0	.750	2.0	30°	.300	NO	8°	3000	3	S-1
FM .8-45°-3-.75	.8	1.0	.750	2.0	45°	.275	NO	8°	3000	3	S-1

Milling Cutter Set MC7-1N W/I comes complete in a Custom-Made Wooden Box with 7 Cutters with Screws, T-10 Torx Screw Driver and 40 Inserts listed below.

Milling Cutter Set MC7-1N Less Inserts		Qty.	Inserts	Grade
CCEM 1.0-0°-5-.75	FM 2.1-15°-5-.75	10	SD322PA	TA23
FM 1-2°-3-.75	FM .9-30°-3-.75	10	SD322PF	TA23
FM .9-15°-3-.75	FM .8-45°-3-.75	10	SD322PA	TA50
FM 1.5-15°-4-.75		10	SD322PA	TAC113