

T&A Tool, Inc.

Manufacturers of Special Carbide Indexable Insert Tooling
 Special Cutter Sampling
 Tel.: 413-743-5917 Fax.: 413-743-7910

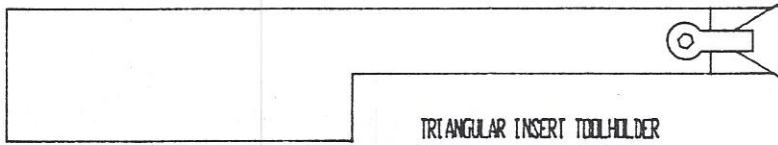

TRIANGULAR INSERT TOOLHOLDER
 INSERT: TPG 430

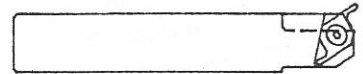

ANGULAR FACE-GROOVING TOOL
 WITH SPECIAL GROOVING INSERT

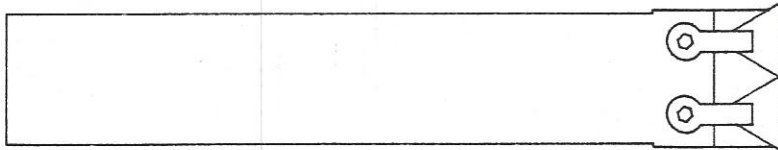

DOUBLE TRIANGULAR INSERT TOOLHOLDER
 INSERT: TPG 430

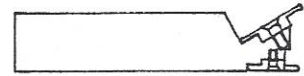

2-INSERT GROOVING TOOL, ALLOWS 2 SEPARATE
 OPERATIONS WITHOUT A TOOL CHANGE

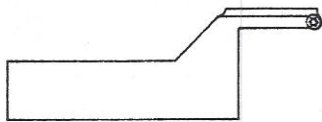

.250 WIDE, FULL RADIUS
 FACE-GROOVING TOOL

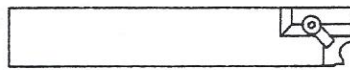

TOOL HOLDER FOR SPECIAL PROFILE INSERT

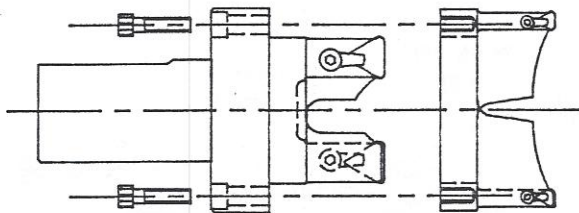

2-PIECE DOUBLE TREPANNING TOOL

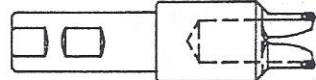

.937 O.D. / .684 I.D. TREPAN TOOL
 SPECIAL .1265 WIDE INSERTS

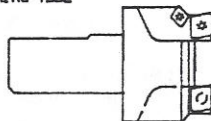

COMBINATION TREPAN / I.D. CHAMFER TOOL
 4 FLUTES, 2 EFFECTIVE

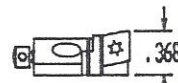

0° LEAD MINI CARTRIDGE
 INSERT: CPGH 21.51
 ALSO AVAILABLE:
 15°, 30°, 45°, 60°

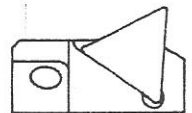

CARTRIDGE FOR SLOTTING
 INSERT: TPG 432
 CARTRIDGE SCREWS INTO TOOL,
 WEDGES USED TO LOCK INSERT

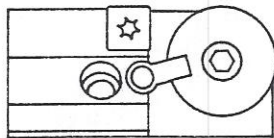

SPECIAL CARTRIDGES FOR 8.5 DIA, 4 EFFECTIVE FLUTE SHELLMILL
 INSERT: RCHT 3209MD
 INSERT: SCMT 432

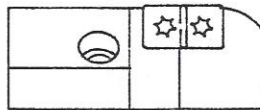

INSERT: SCMT 432 (2)

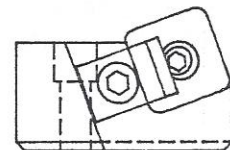

DOUBLE-NEGATIVE CARTRIDGE FOR SHANK 868
 SPECIAL SHIM SEAT AND CLAMP



RADIALLY ADJUSTABLE CARTRIDGE FOR BORING
 INSERT: TPGD 21.50

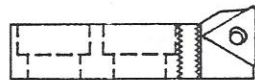

ADJUSTABLE O.D. TURNING CARTRIDGE

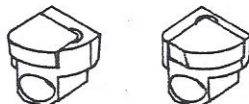

SPECIAL CARTRIDGES FOR LARGE SLOTTING CUTTER
 LOCATING KEYS ON BOTTOM
 CARTRIDGES SCREW ON TO TOOL
 SPECIAL INSERTS LOCKED USING WEDGES

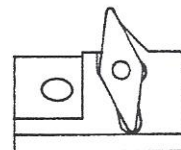

CARTRIDGE FOR SLOTTING CUTTER
 INSERT: VPGA 443
 CARTRIDGE SCREWS INTO TOOL,
 WEDGES USED TO LOCK INSERT

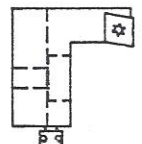

HOLLOW MILLING CARTRIDGE
 RADIALLY ADJUSTABLE
 INSERT: CPGH 21.5.008

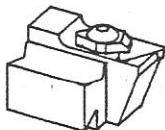

DOVETAIL-MOUNT TURNING CARTRIDGE
 INSERT: TPG 322

T&A Tool, Inc.

Manufacturers of Special Carbide Indexable Insert Tooling
Special Cutter Sampling
Tel.: 413-743-5917 Fax.: 413-743-7910

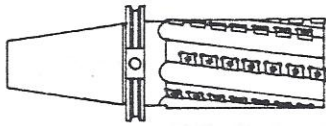

Ø3.0, 5.25 L.D.C. ENDMILL WITH INTEGRAL CAT-50 SHANK

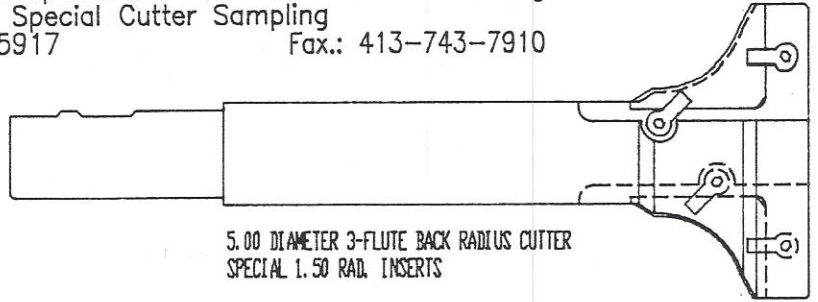

5.00 DIAMETER 3-FLUTE BACK RADIUS CUTTER
SPECIAL 1.50 RAD. INSERTS

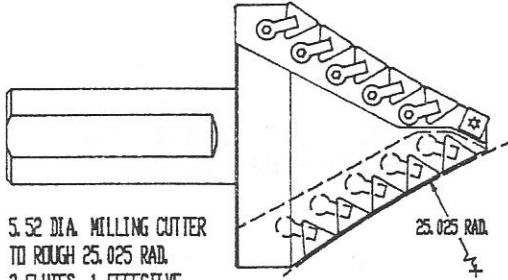

5.52 DIA. MILLING CUTTER TO ROUGH 25.025 RAD.
2 FLUTES, 1 EFFECTIVE INSERTS ON POSITIVE HELIX

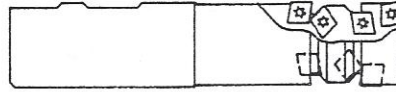

SPECIAL PROFILE TOOL USED FOR THROUGH BORING AND INTERNAL CIRCLE INTERPOLATION

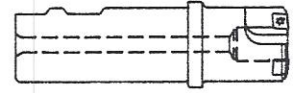

.505 DIA. 3-FLUTE ROUGH HOLLOW MILL

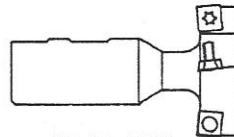

BACK MILLING CUTTER

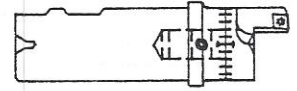

.495 DIA. FINISH HOLLOW MILL ADJUSTABLE ON ECCENTRIC SHANK

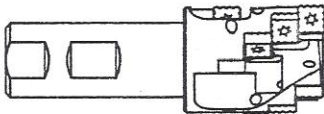

Ø1.5, 1.5 L.D.C. ROUGHING ENDMILL
SNMC 322B INSERTS RADIALLY SPACED
3 EFFECTIVE FLUTES

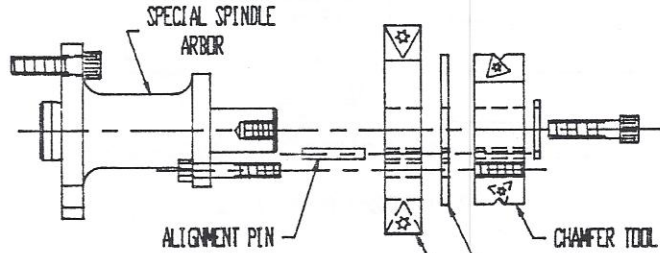

COMBINATION FACE OFF / CHAMFER TOOL
SPECIAL SPINDLE ARBOR
FACING TOOL: 6 EFFECTIVE FLUTES
CHAMFER TOOL: 3 EFFECTIVE FLUTES

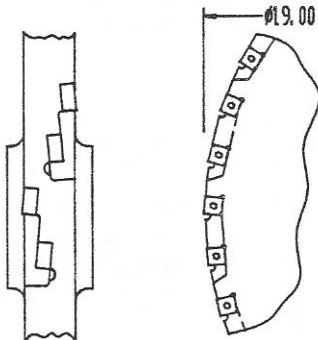

19.00 DIA., 1.00 WIDE SLOTTING CUTTER
40 INSERTS, 10 EFFECTIVE CUTTING EDGES

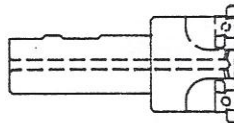

LEFT HAND UNDERCUT TOOL WITH THROUGH COOLANT
3 EFFECTIVE FLUTES



REPLACEABLE HEAD SLOTTING CUTTERS,
.188 - .325 WIDE / 2.0 - 4.25 DIA.

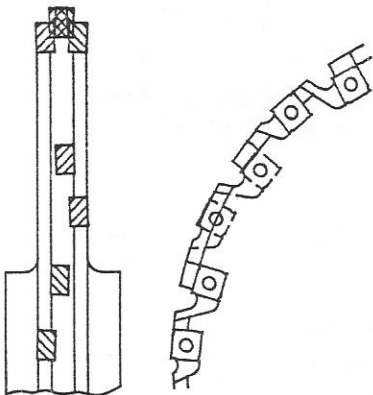

12.00 / 11.50 DIAMETER SLOTTING CUTTER
32 INSERTS, 8 EFFECTIVE TEETH

5/8 I.C., SPECIAL PROFILE

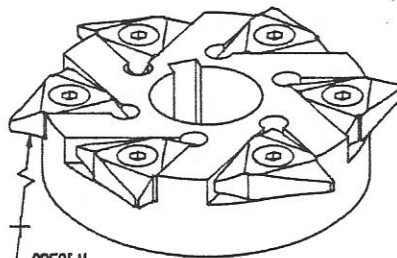

SPECIAL 1.345 RAD.

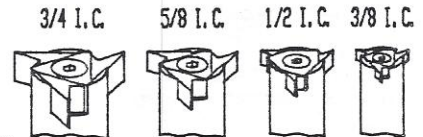

GROOVE / THREAD MILLING CUTTERS
SINGLE AND MULTIPLE INSERT DESIGNS
SPECIAL INSERTS GROUND WHERE APPLICABLE

T&A Tool, Inc.

Manufacturers of Special Carbide Indexable Insert Tooling

Special Cutter Sampling

Tel.: 413-743-5917

Fax.: 413-743-7910

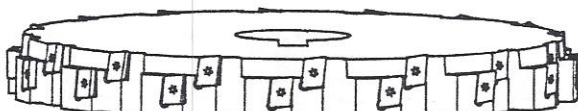

10.00 DIA. FACEMILL / 5° SHOULDER MILL
16 EFFECTIVE FLUTES

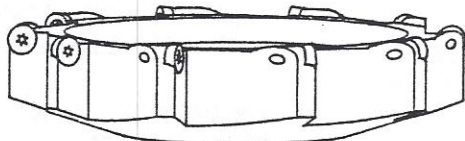

8.00 DIA. FACEMILL WITH .250 RAD.
SPECIAL 75mm PILOT, 10 EFFECTIVE FLUTES

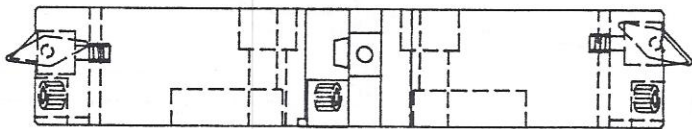

12.00 DIA., 52° INCLUDED ANGLE SLOTTING CUTTER
SPECIAL SCREW-IN CARTRIDGES FOR 35° DIAMOND INSERT
16 FLUTES, 8 EFFECTIVE

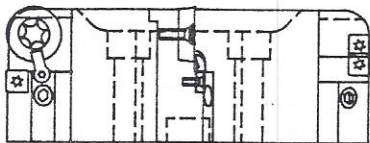

8.50 DIA., 1.95 D.D.C. FACEMILL WITH .63 RAD.
SPECIAL SCREW-IN CARTRIDGES
8 FLUTES, 4 EFFECTIVE

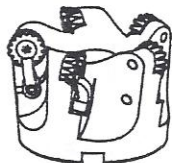

3.0 DIA., 5-FLUTE SHELL/RAMP MILL

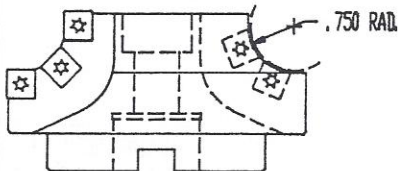

5.25 DIA. SHELL MILL TO ROUGH 3/4" RADIUS
4 FLUTES, 2 EFFECTIVE

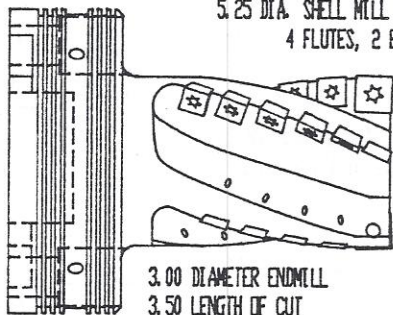

3.00 DIAMETER ENDMILL
3.50 LENGTH OF CUT
SPECIAL 60mm PILOT
AIR GLAND AND AIR HOLES THROUGH TOOL
INSERTS ON HIGH-POSITIVE HELIX

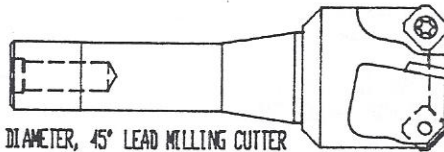

2.0 DIAMETER, 45° LEAD MILLING CUTTER
3 EFFECTIVE FLUTES, R-9 STYLE SHANK,
DOUBLE POSITIVE GEOMETRY REDUCES CUTTING FORCES
FOR LOW HORSEPOWER MACHINES

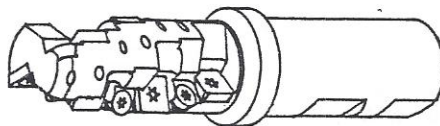

#980 ROUGHING ENDMILL
2-1/4 LENGTH OF CUT

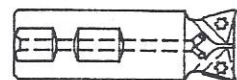
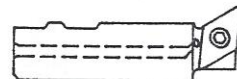

SPECIAL DOVETAIL CUTTERS,
SINGLE AND MULTIPLE INSERT STYLES
10°, 15°, 20°, 30° IN STOCK

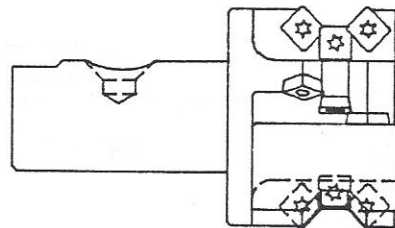

MILL & CHAMFER TOOL
4 EFFECTIVE FLUTES

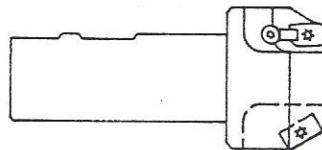

30° LEAD, FLAT BOTTOM ENDMILL
4 FLUTES, 2 EFFECTIVE

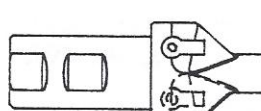

82° PILOTED COUNTERSINK
TPG 432 INSERTS

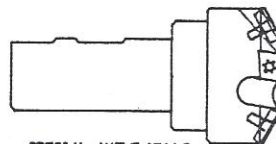

SPECIAL ANGLE MILLS,
ALL ANGLES AND DIA.'S



82° C SINK TOOL
SINGLE AND MULTIPLE INSERT STYLES

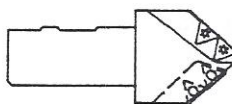

45°, 3-FLUTE CHAMFER / BACK CHAMFER MILL
SINGLE AND MULTIPLE INSERT STYLES

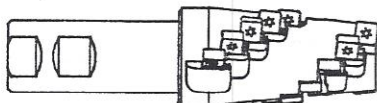
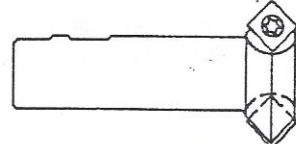

#1.785, 5°42' TAPERED ENDMILL
INSERTS ON NEGATIVE HELIX WITH OVERLAPPING RADII
2-15/16 L.D.C., 2 EFFECTIVE FLUTES



CENTER-CUTTING, POSITIVE HELIX
ENDMILL FOR COMPOSITE



45° CHAMFER MILL WITH 1/2" SHANK
#3/8 GUIDE BEARING WITH #3 SHCS
USED IN A MANUAL ROUTER TO CHAMFER
STEEL BY HAND

T&A Tool, Inc.

Manufacturers of Special Carbide Indexable Insert Tooling

Special Cutter Sampling

Tel.: 413-743-5917

Fax.: 413-743-7910

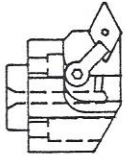

27°/30° BORING HEAD
WITH THROUGH COOLANT

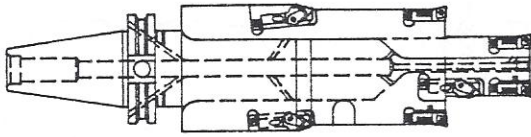

3-DIAMETER ROUGH/FINISH
BORE AND CHAMFER
SPECIAL CHAMFER CARTRIDGES
THROUGH COOLANT, CAT-40 SHANK

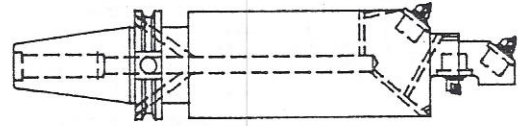

3-DIAMETER FINISH BORING TOOL
CAT-40 SHANK, TENTH-SET CARTRIDGES,
"DIN-FORM B" COOLANT HOLES

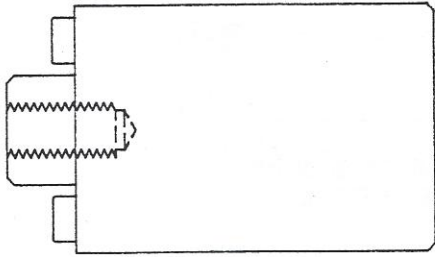

EXTENDED-LENGTH NMTB-40
SHELL MILL ADAPTER

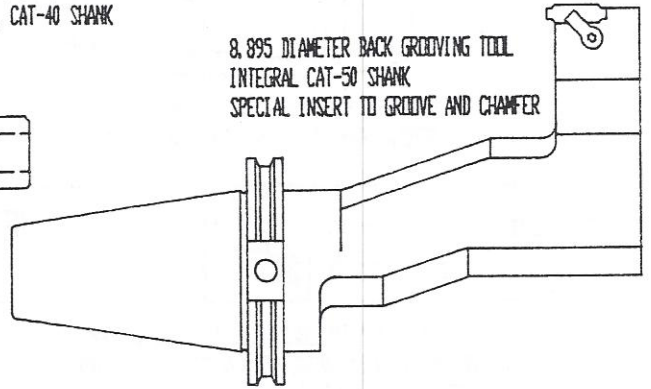

8.895 DIAMETER BACK GROOVING TOOL
INTEGRAL CAT-50 SHANK
SPECIAL INSERT TO GROOVE AND CHAMFER

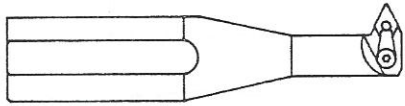
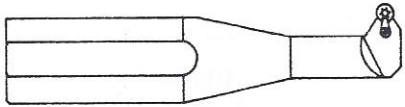

CARBIDE INSERT BORING BARS FOR PROFILING
ROUND INSERT STYLE & 55° DIAMOND INSERT STYLE

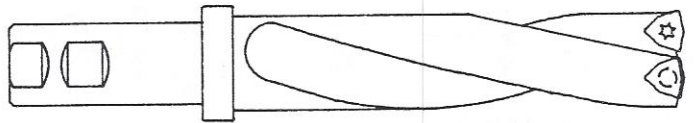

HELICAL FLUTE INDEXABLE DRILLS: STUBBY, REGULAR, AND EXTENDED LENGTHS
WITH THROUGH COOLANT

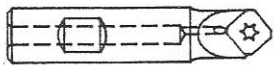
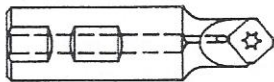

CARBIDE INSERT SPOTDRILLS, 100° INCLUDED ANGLE
1" OR 3/4" SHANK, WITH OR WITHOUT THROUGH COOLANT

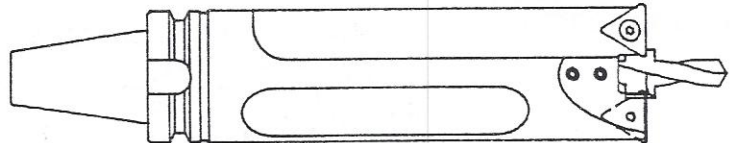

2-5/8 DIA. CARBIDE INSERT COUNTERBORE TOOL
1/2" HIGH SPEED STEEL STEP DRILL AND BT-40 SHANK

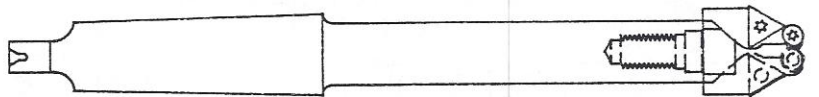

REPLACEABLE-HEAD DRILL AND COUNTERSINK TOOL,
USED TO ENTER WORKPIECE AT A 45° ANGLE
MORSE #4 TAPER SHANK

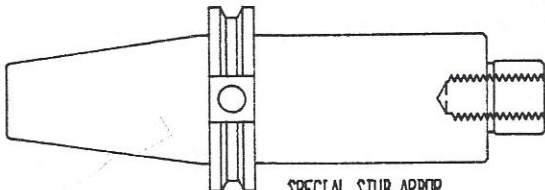

SPECIAL STUB ARBOR
CAT-40 SHANK, 1.000 PILOT

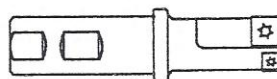

FLAT BOTTOM DRILL
2 EFFECTIVE CUTTING EDGES
AT OUTSIDE DIAMETER

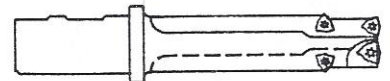

.880 DIAMETER / 1.000 DIAMETER, 45° LEAD
INDEXABLE STEP DRILL

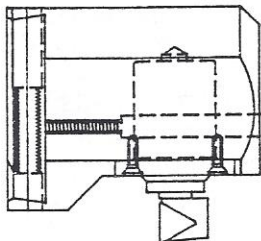

PRECISION BACK-BORING HEAD, ALLOY ALUMINUM BODY

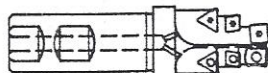

DRILL / C BORE / C BORE TOOL
WITH THROUGH COOLANT

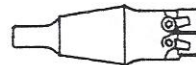

CENTER-CUTTING SPOTFACE TOOL
FLAT BOTTOM, .875 DIAMETER
#3 STUB TAPER SHANK

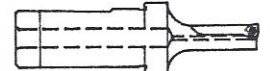

CARBIDE INSERT DRILLS, SPECIAL
DIAMETERS DOWN TO .450"
WITH THROUGH COOLANT