

# T&A Tool, Inc.

Manufacturers of Special Carbide Indexable Insert Tooling

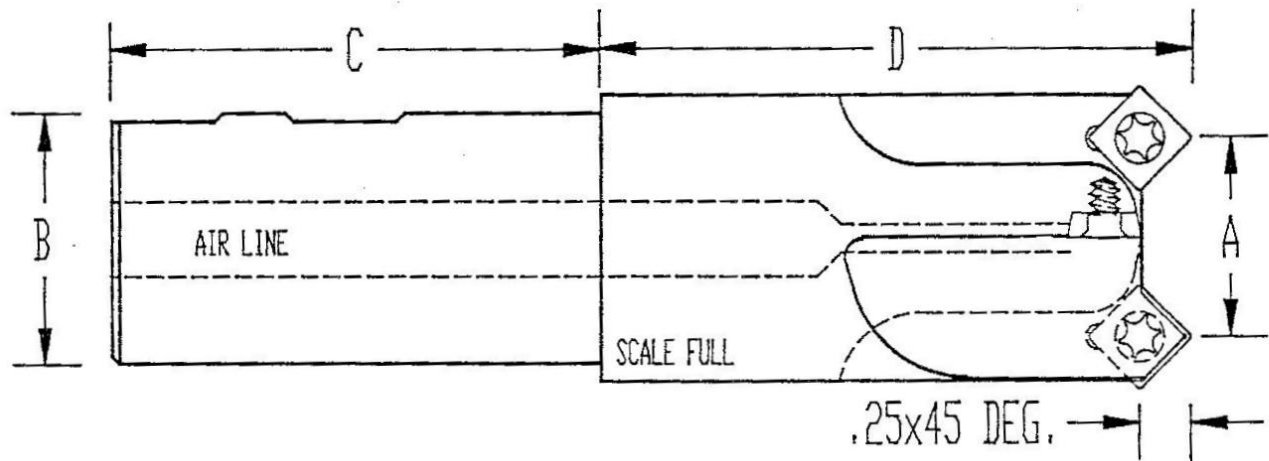

## NEW AND NOW AVAILABLE RAMP MILLING CUTTER

EASIER, FASTER, ECONOMICAL & REQUIRES LESS HORSEPOWER,  
WHEN MACHINING OUT POCKETS OR CAVITIES ON CNC MACHINES.  
INSTEAD OF USING HIGH HORSEPOWER MACHINES, VERY EXPENSIVE  
LARGE CARBIDE INSERT ROUGHING END MILLS, AND A SLOW FEED

NOW YOU CAN USE THE NEW T&A TOOL RAMP MILL, BY SIMPLY  
PROGRAMING IN A RAMP DEPTH, AND A PATH TO COVER THE SURFACE  
OF THE POCKET OR CAVITY. REPEAT PROGRAM TO DESIRED DEPTH.

WITH AIR THROUGH TOOL WHERE APPLICABLE THERE IS NO  
PROBLEM RECUTTING CHIPS TO CAUSE PREMATURE CARBIDE INSERT  
WEAR.

CUTTERS MADE TO SUIT YOUR JOB, MADE OF ALLOY STEEL, HEAT  
TREATED, FINISH GROUND & BLACK OXIDE FINISHED, DELIVERED  
IN LESS TIME THAN SOME COMPANIES STANDARDS (2-3 WEEKS).

TEL. 413-743-5917 FAX. 413-743-7910

\0\1545RM

# T&A Tool, Inc.

Manufacturers of Special Carbide Indexable Insert Tooling

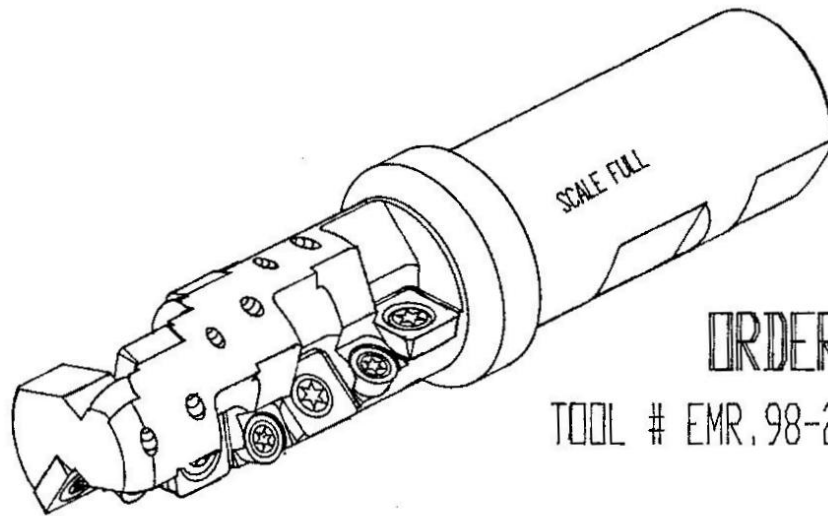

ORDER

TOOL # EMR.98-2.25-14-1

NEW & IN STOCK

ROUGHING END MILL .980 DIA.

2.250 LENGTH OF CUT

STANDARD CARBIDE INDEXABLE INSERTS

## INSERT INFORMATION

(7) ROUND INSERT RCMT 22 SCREW 03 M 2.5 TORX T-7

(7) SQUARE INSERT SD 322 SCREW S1 M 3.5 TORX T-10

SPECIAL CUTTERS QUOTED ON REQUEST  
DEL. 2 WEEKS TO 6 WEEKS

TEL 413-743-5917

FAX 413-743-7910

1017400

# T&A Tool, Inc.

Manufacturers of Special Carbide Indexable Insert Tooling

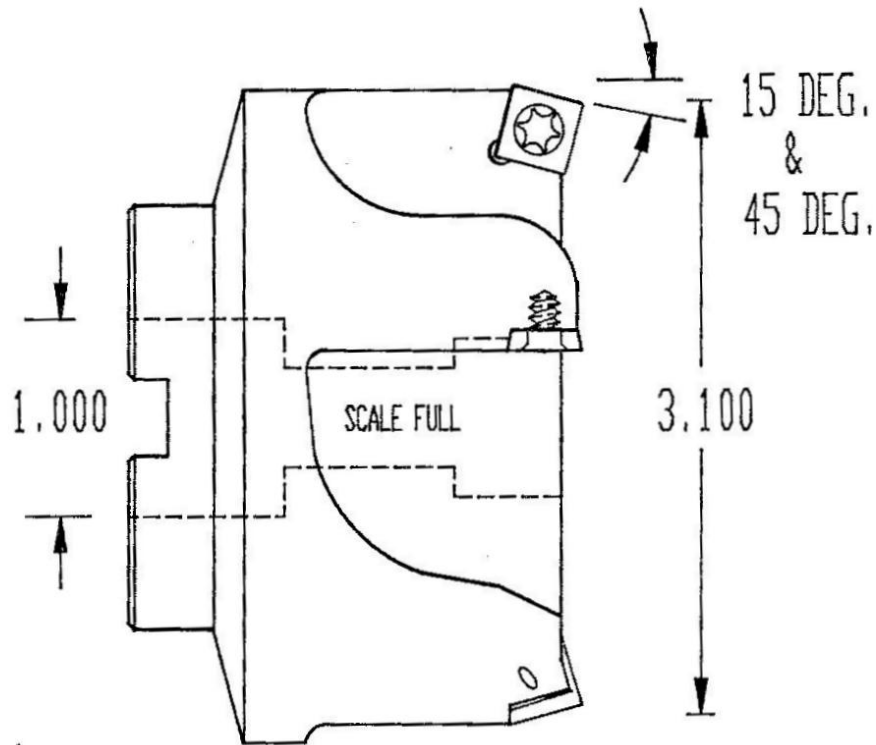

3.1 DIA.  
15 & 45 DEG.

IN STOCK 5 FLUTE 3/8 I.C. INSERT

ORDER # FM 3.1-15-5-1.0  
FM 3.1-45-5-1.0

## INSERTS IN STOCK

SD 321P	C-2	C-5	C-7 TIN
SD 322P	C-2	C-5	C-7 TIN
SD 323P	*	C-5	*
SD 324P	*	C-5	*
SD 32 PF	C-2	*	C-7 TIN WIPER FLAT

TEL. 413-743-5917

FAX. 413-743-7910

\* NON-STOCK STD.

\0\155381

# T&A Tool, Inc.

Manufacturers of Special Carbide Indexable Insert Tooling

82° C'SINK 1/4 TO 1 5/8 DIA.  
 3 FLUTE 6 INDEXABLE INSERTS  
 ALLOY STEEL HEAT TREATED

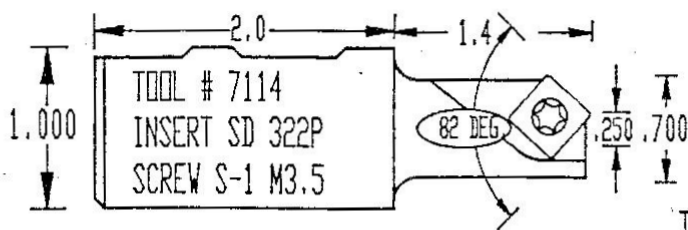
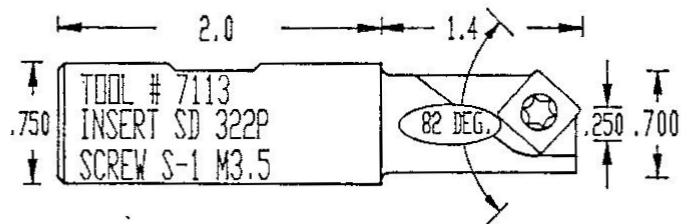
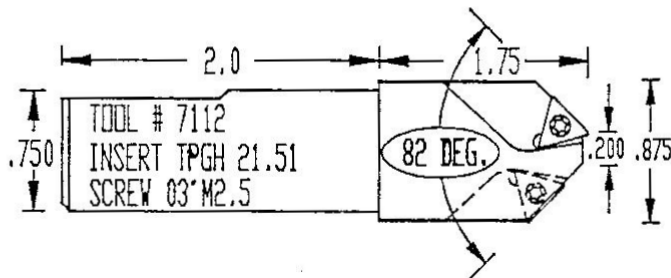
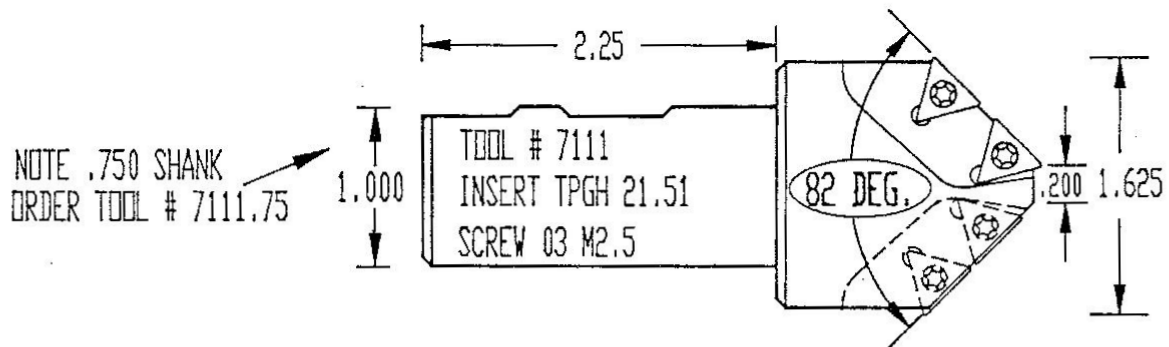

TORX DRIVER T-7 INSERT TPGH 21.51  
 TORX DRIVER T-10 INSERT SD 322P

SPECIAL CUTTERS QUOTED ON REQUEST  
 DEL. 2 WEEKS TO 6 WEEKS

TEL. 413-743-5917  
 FAX 413-743-7910

9/1/92  
 \0\7111

**T&A TOOL, Inc.**

73 SUMMER ST.  
ADAMS, MA 01220  
TEL. (413) 743-5917  
FAX (413) 743-7910

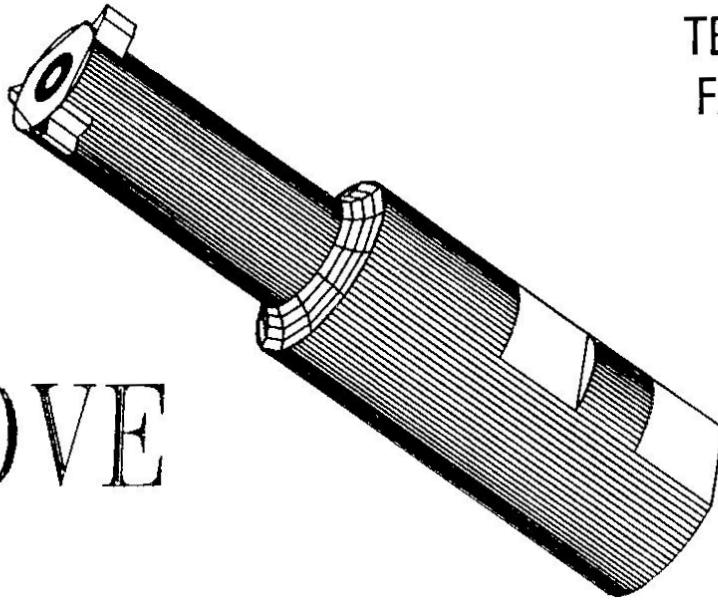

**GROOVE  
&  
THREAD MILL** (3 FLUTE EFFECTIVE)

TOOL #	DEPTH OF GROOVE		MIN. I.D.		SHANK DIA.		
	INS. SIZE	WIDTH OF GROOVE	MIN.	MAX.	REACH		
GT1	.375	.040	.030	.125	.580	1.500	.750
GT2	.500	.100	.060	.187	.850	1.750	1.000
GT4	.750	.200	.125	.375	1.200	2.000	1.250

INSERT INFORMATION			GRADES		
GT1	.375	= TPMC 32. (SPECIFY WIDTH)	C-2	C-5	C-7 TIN COATED
GT2	.500	= TPMC 43. (SPECIFY WIDTH)	C-2	C-5	C-7 TIN COATED
GT4	.750	= TPMC 66. (SPECIFY WIDTH)	C-2	C-5	C-7 TIN COATED

(NOTE: THREADING INSERTS LARGER DIA.)  
SPECIALS QUOTED UPON REQUEST

# T&A Tool, Inc.

Manufacturers of Special Carbide Indexable Insert Tooling

NEW, AND NOW AVAILABLE  
45 DEGREE CHAMFER / MILLING CUTTER

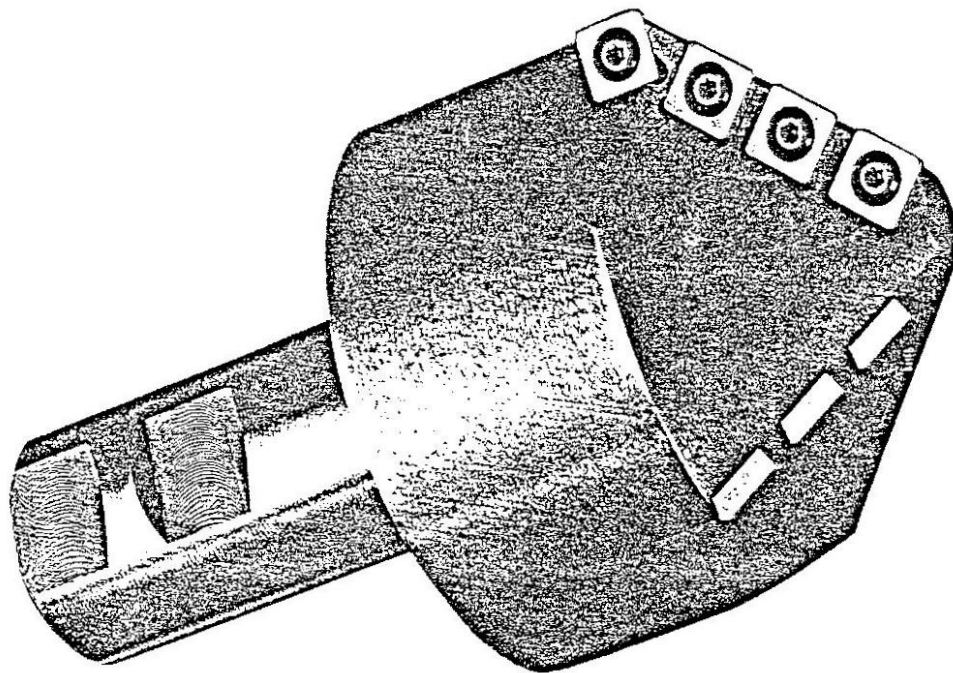

TOOL # EM 3-45-10-1.250  
MAX. DIA.      ANGLE      SHANK DIA.      QTY. OF INSERTS

MINIMUM DIA. 5/8  
MAXIMUM DIA. 3.0

TEL. 413-743-5917  
FAX. 413-743-7910

SPECIALS QUOTED ON REQUEST 12/15/92  
DEL. 2 WEEKS TO 6 WEEKS \0\AD7100



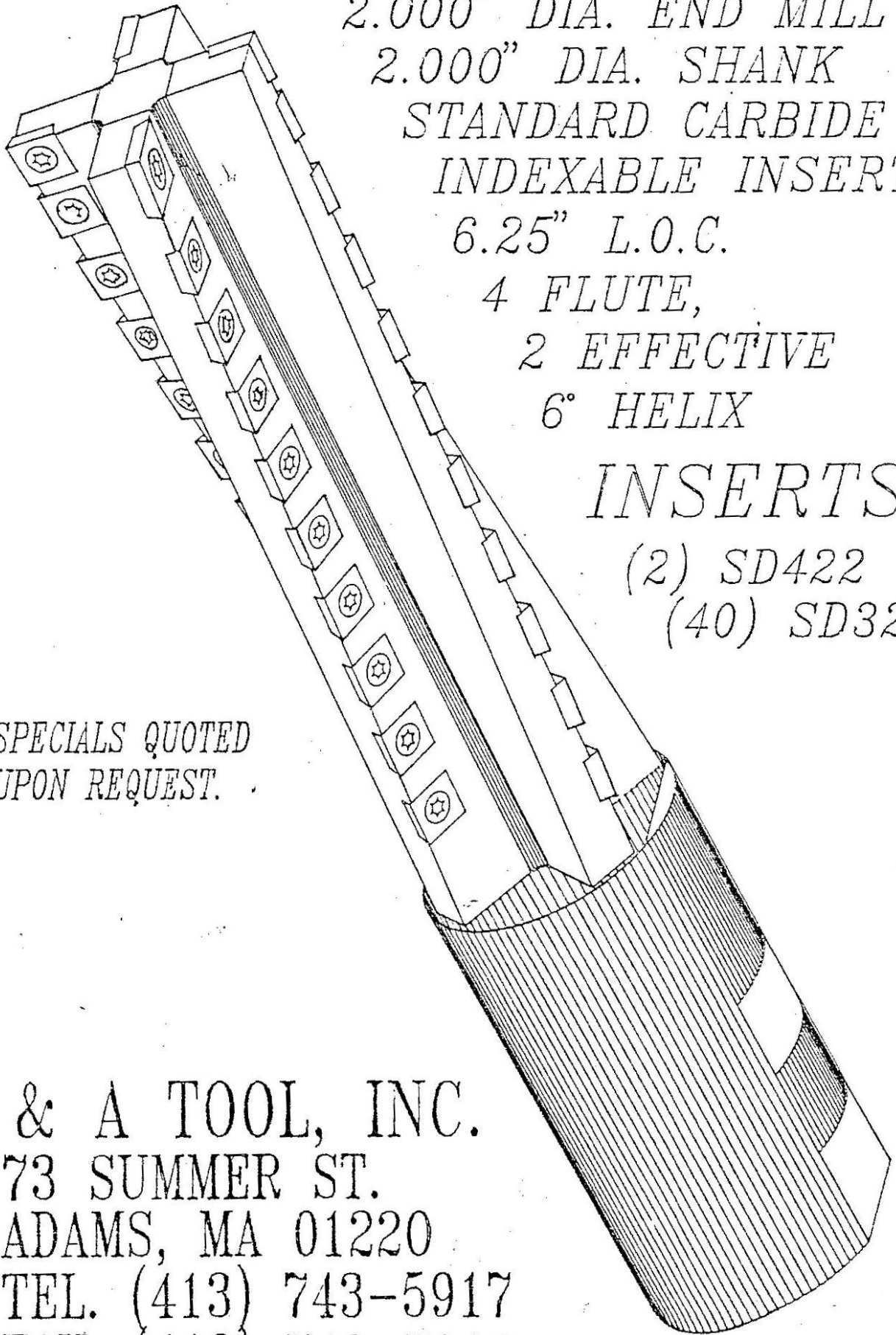

2.000" DIA. END MILL  
2.000" DIA. SHANK  
STANDARD CARBIDE  
INDEXABLE INSERTS.

6.25" L.O.C.

4 FLUTE,  
2 EFFECTIVE  
6° HELIX

INSERTS

(2) SD422

(40) SD322

SPECIALS QUOTED  
UPON REQUEST.

T & A TOOL, INC.

73 SUMMER ST.

ADAMS, MA 01220

TEL. (413) 743-5917

FAX. (413) 743-7910

# T&A Tool, Inc.

Manufacturers of Special Carbide Indexable Insert Tooling

IN STOCK

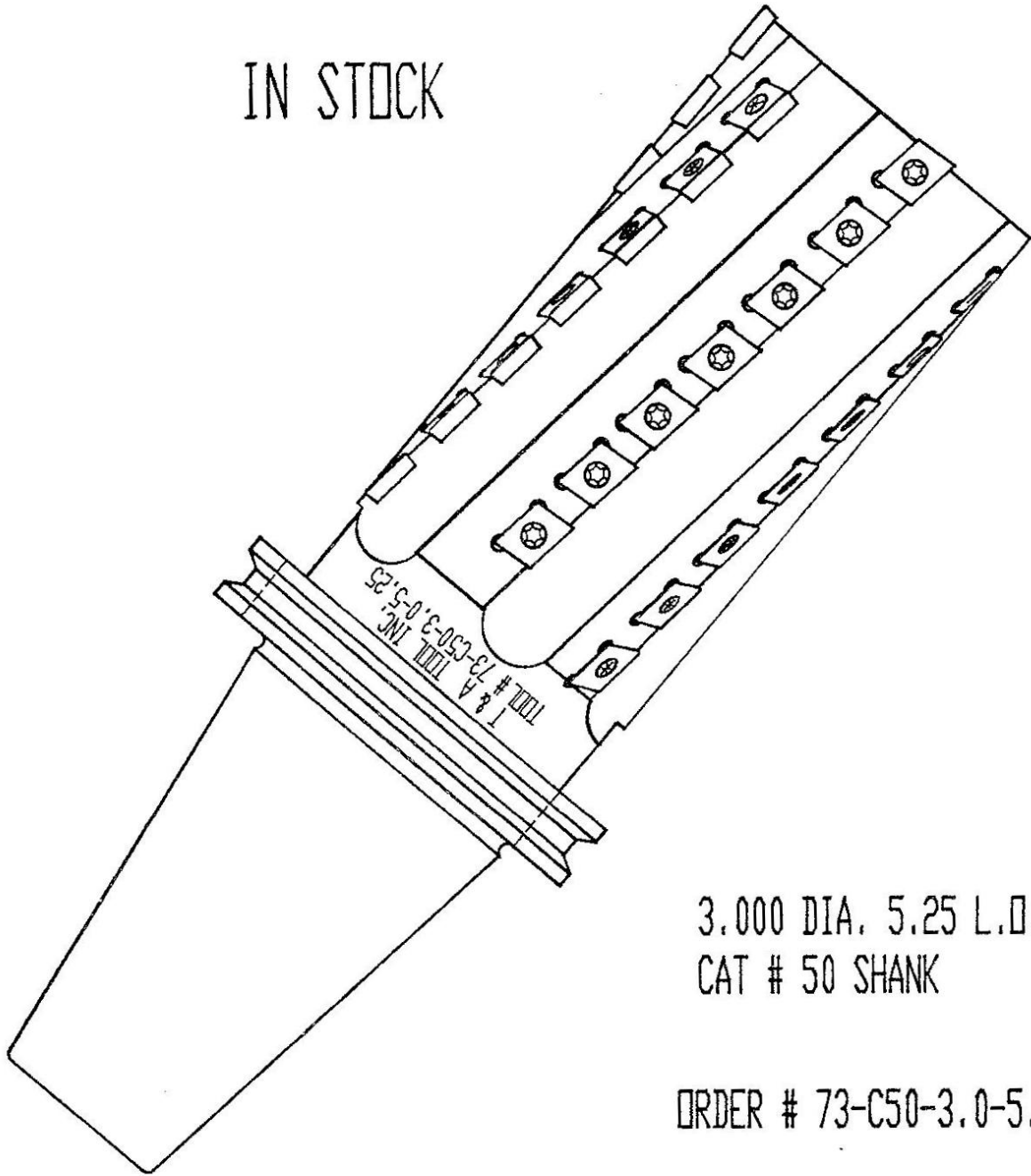

3.000 DIA. 5.25 L.O.C.  
CAT # 50 SHANK

ORDER # 73-C50-3.0-5.25

TEL. 413-743-5917  
FAX. 413-743-7910

SPECIALS QUOTED ON REQUEST  
DEL. 2 WEEKS TO 6 WEEKS

9/1/92  
VAD-5



# T&A Tool, Inc.

Manufacturers of Special Carbide Indexable Insert Tooling

## 60 DEG. LEAD IN STOCK

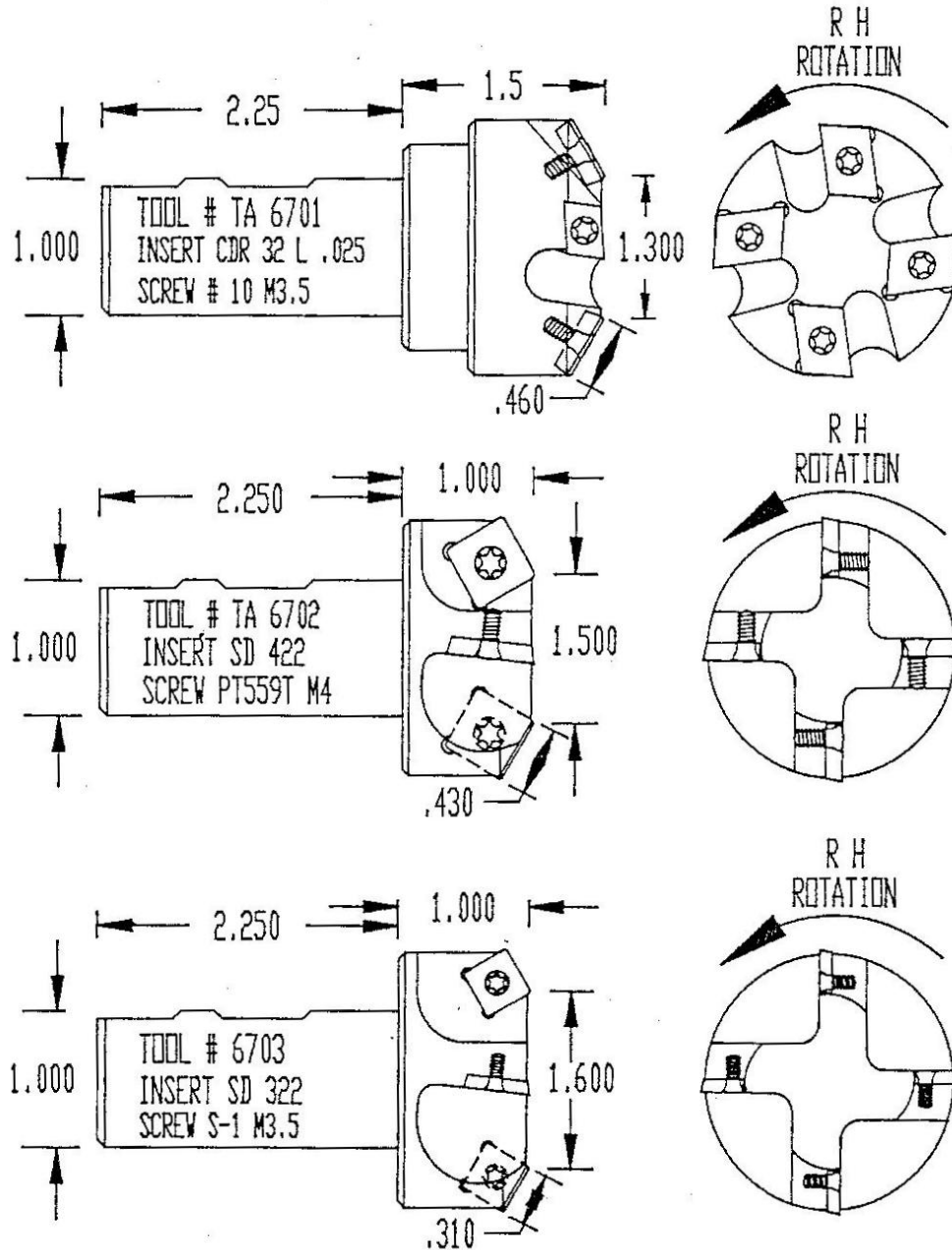

TEL. 413-743-5917  
 FAX. 413-743-7910

SPECIALS QUOTED ON REQUEST  
 DEL. 2 WEEKS TO 6 WEEKS

9/1/92  
 10\6700A

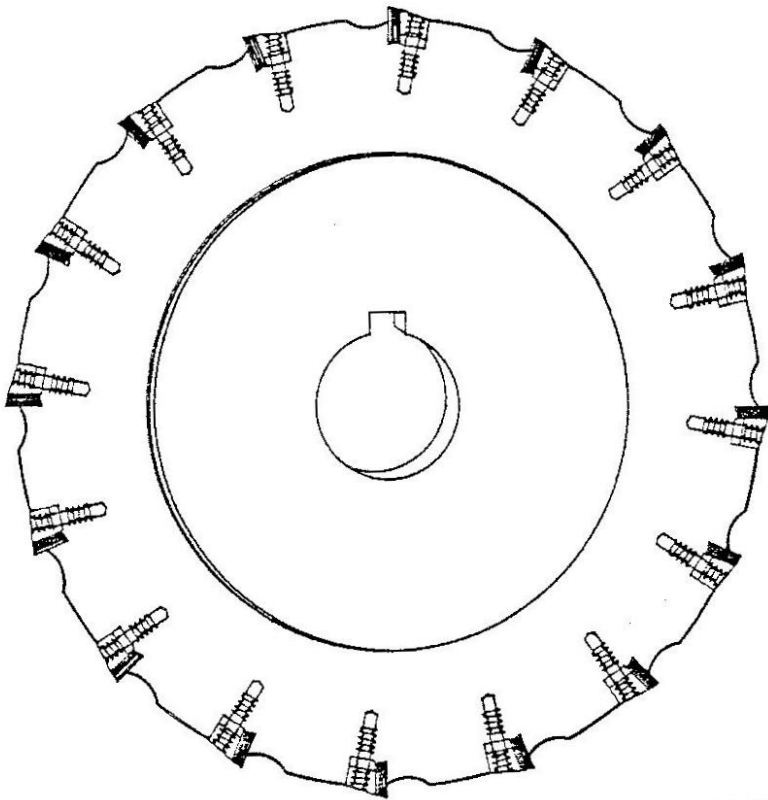

SLOTING CUTTERS

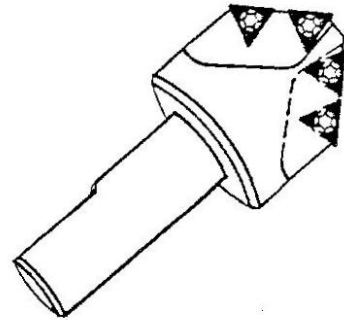

CHAMFER CUTTERS

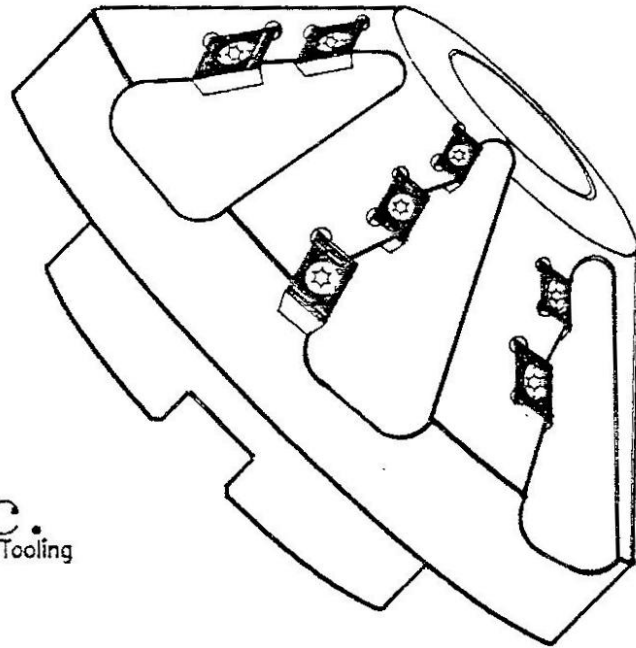

ANGLE MILLING CUTTERS

**T&A Tool, Inc.**  
Manufacturers of Special Carbide Indexable Insert Tooling

ESTABLISHED 1983

SPECIALIZING IN  
DESIGN & MANUFACTURING OF STANDARD &  
SPECIAL CARBIDE INDEXABLE INSERT CUTTING TOOLS

73 SUMMER ST.  
ADAMS, MASS. 01220

# T&A Tool, Inc.

Manufacturers of Special Carbide Indexable Insert Tooling

**SLOTING CUTTERS**  
 WIDTHS .188 THROUGH .325  
 HARDENED REPLACEABLE HEADS  
 HARDENED & GROUND SHANKS

SHOWN 1/2 SCALE  
 4.0

STYLE A&B .500 SQ. DRIVER  
 STYLE C D&E .750 SQ. DRIVER

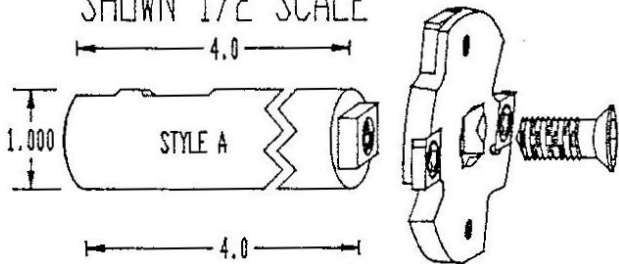

STYLE(A) 2.0 THROUGH 2.75 DIA.

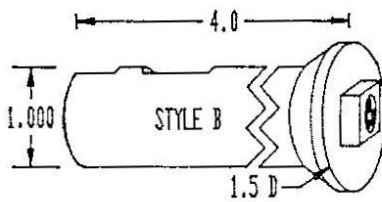

STYLE(B) 2.5 THROUGH 3.25 DIA.

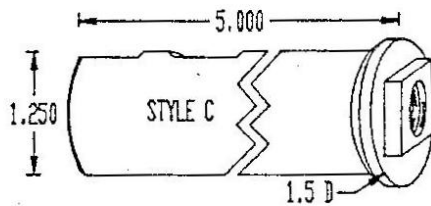

STYLE(C) 2.5 THROUGH 3.25 DIA.

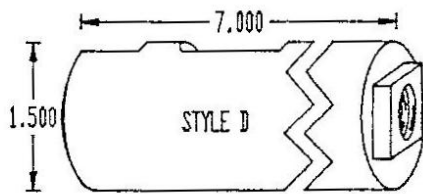

STYLE(D) 2.5 THROUGH 3.25 DIA.

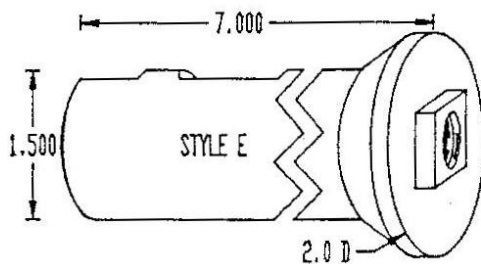

STYLE(E) 3.0 THROUGH 4.25 DIA.

**INSERTS**

SECO

SANDVIK

VALENITE

TEL. 413-743-5917  
 FAX. 413-743-7910

SPECIALS QUOTED ON REQUEST  
 DEL. 2 WEEKS TO 6 WEEKS

9/1/92  
 1016600

# T&A Tool, Inc.

Manufacturers of Special Carbide Indexable Insert Tooling

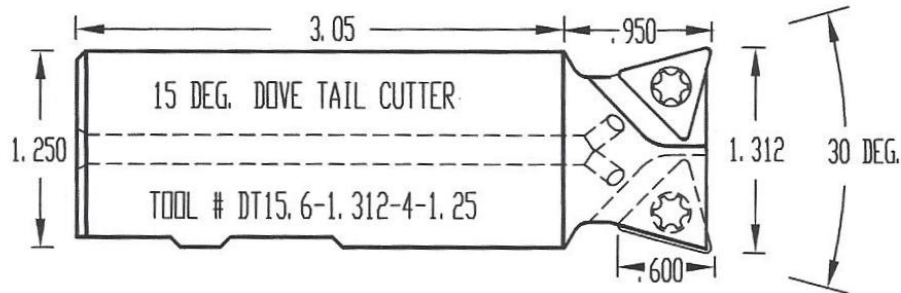

INSERT  
TPGH 321/2  
TD 6 P 322

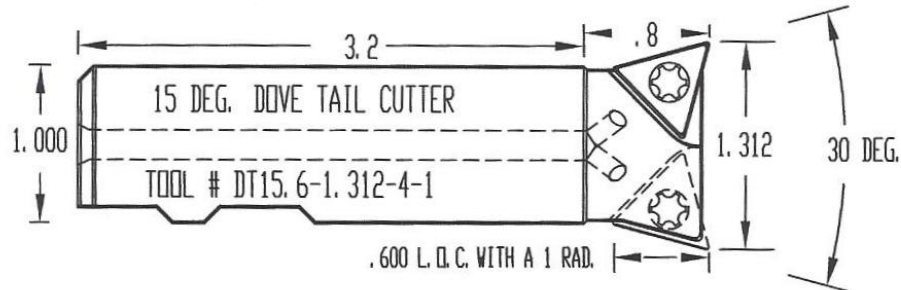

INSERT  
TPGH 321/2  
TD 6 P 322

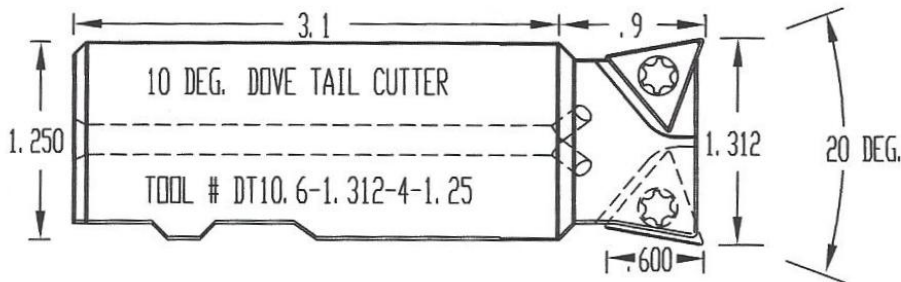

INSERT  
TPGH 321/2  
TD 6 P 322

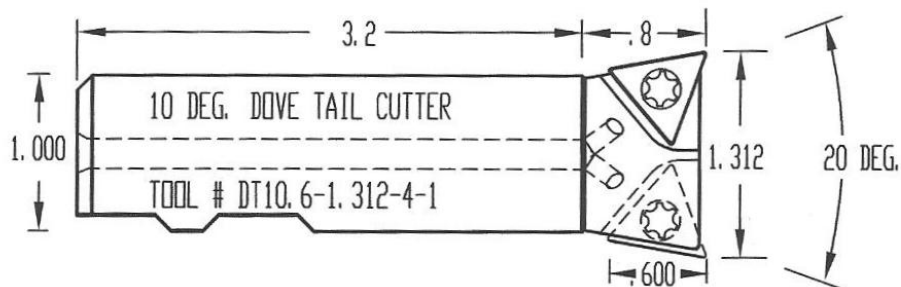

INSERT  
TPGH 321/2  
TD 6 P 322

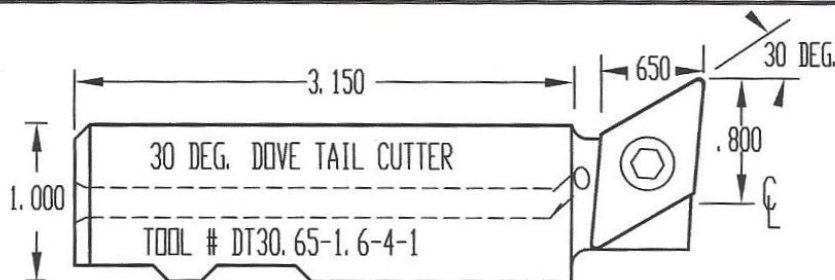

INSERT  
DPGA 532

SCALE .8=1 \\\\DVT1